



Lumin Smart Panel - Indoor

**SERVICE UPSIZE
AVOIDANCE
DOCUMENTATION
AND INSTALLATION
MANUAL**



U.S. Patent No. 10,109,987

U.S. Patent No. 10,467,712

Canadian Patent No. 3,050,702

U.S. and International Patent Applications Pending.

® U.S. Registered Trademark.

Copyright © 2022 Coulomb, Inc. (DBA Lumin). All rights reserved.

TABLE OF CONTENTS

INTRODUCTION.....	1
READ BEFORE USE	2
Warnings	2
SYSTEM DESIGN CONSIDERATIONS	3
INSTALLATION.....	4
Items in the Box.....	4
Required Materials (Not Included).....	5
Required Tools.....	6
Hardware Installation Overview.....	7
Hardware Installation Steps	8
Configuration and Account Setup.....	30
TROUBLESHOOTING AND REPAIRS	33
End User	33
Qualified Installer	33
OPERATIONAL INFORMATION	34
PRODUCT SPECIFICATIONS.....	35
LIMITED WARRANTY FOR LUMIN SMART PANEL.....	36
RADIO FREQUENCY STATEMENT	37



This page intentionally left blank

INTRODUCTION

Welcome! The Lumin Smart Panel (LSP) is a standalone product that extends the capability of an existing circuit breaker panel (or “electrical panel”) by providing measurement and remote control of up to twelve (12) circuits in a home or building. The function of the circuit breaker panel remains the same and is not impacted. The LSP securely and safely transmits real-time consumption information to the cloud via Ethernet connection (preferred) or customer WiFi.

This product is intended only to serve as an Energy Management System with overload control. It can be utilized to limit the amount of current on a busbar or conductor and reduce the need for upsized equipment when adding new loads. This cannot be used to manage solar and storage in a grid outage.

Data and system controls can be accessed via the Lumin Energy app (<https://get.lumin.energy>) or the web-based Lumin dashboard (<https://lumin.energy>). The Lumin Energy app gives customers insights into their energy consumption, as well as providing the user with the ability to monitor and prioritize their energy use remotely.

NOTE: A Lumin Smart Panel will not function as designed until it is fully commissioned. It is the responsibility of the installer to perform both the physical installation and the online setup/commissioning process. Refer to pg. 30 to begin the setup process. All qualified persons installing this product must complete Lumin Certified Installer Training prior to installation. Only Certified Installers can access and change current limiting settings. Scan below to register for training.



Need help? For installation assistance please contact Lumin by e-mail at support@luminsmart.com or by phone at 1-888-421-0616 (North America).



DANGER: HAZARDOUS VOLTAGES PRESENT DURING INSTALLATION AND SERVICING. PRECAUTIONS AND QUALIFICATIONS REQUIRED. REFER TO THE FOLLOWING PAGE.



DANGER: TENSIONS DANGEREUSES PRÉSENTES LORS L'INSTALLATION ET L'ENTRETIEN. PRÉCAUTIONS ET QUALIFICATIONS REQUISES. REPORTEZ-VOUS À LA PAGE SUIVANTE.



READ BEFORE USE

The LSP is compatible with both flush-mounted (i.e., set within drywall) existing electrical panels and surface-mounted electrical panels. Please determine which electrical panel type the LSP will be connecting to and follow the corresponding installation steps outlined in this manual. Devices with LSP-12-IR and TPU-IR model numbers must be installed indoors. Please review the product's technical ratings and specifications (pg. 35) to confirm it is suitable for your application prior to installation.

NOTE: The *LSP Circuit Label & CT Table* (provided with the LSP) must be completed for setup and delivered to the home/building owner upon the successful installation of the LSP.



Warnings

LSP installation and servicing involves dangerous voltages that can cause injury or death. In addition to specific instructions accompanied by the  symbol throughout this booklet and product labeling, observe the following safety precautions:

- Installation and servicing must be conducted by qualified persons, according to local and national electrical codes
- Lumin Certified Installer training is required for installation and servicing. The installation cannot be completed without Certified Installer credentials.
- Review entire manual before starting the installation or servicing
- Personal protective equipment should be worn when installing or servicing the product
- Do not install or operate the LSP other than intended or outside the conditions specified on pg. 35
- Do not open, attempt to access, or touch any internal product parts — dangerous voltages would be exposed even if main service feed is disconnected
- Do not use the product if it is damaged or appears to be damaged
- Use only the wires and cables supplied with the product
- Power relays are evaluated for 100,000 cycles at a 1.5 HP inductive load (e.g., motors) — larger loads of this type may result in premature relay failure
- The product warranty does not cover damage due to lightning. Lumin recommends the installation of a whole-house surge protector to prevent product damage due to lightning strike

SYSTEM DESIGN CONSIDERATIONS

- The LSP should be mounted so that the connected electrical panel is within reach of the LSP's flexible conduit nipple. Depending on orientation, the nipple extends between 7" and 17" beyond the edge of the LSP enclosure. Ensure that the load center has adequate wiring space for LSP conductors and connections. Suitable junction boxes and conduit may be used to route and/or extend LSP conductors if needed. For voltage drop calculations, assume LSP conductors add 15 one-way-feet to the circuit.
- An LSP requires an always-on internet connection, either via **Ethernet (preferred if available)** or 2.4 GHz WiFi. Make sure your router is configured with 2.4 GHz enabled. The LSP is only able to connect to 2.4 GHz WiFi networks.
- **Controlling the circuit that powers the Internet connection is not recommended;** manual control of the LSP will be lost when this circuit is switched off.
- The Panel Guard overload control functionality will be most effective when used to shed heavy (greater than 15 A) two-pole loads, especially thermostatic loads like water heating and HVAC as well as battery charging loads such as electric vehicle charging equipment. **More information about circuit selection is provided in the required Lumin Certified Installer Training.**
- The LSP **does not** replace the need for standard circuit breakers. LSP **does not** provide overcurrent protection, ground fault protection, arc fault detection, or other safety functions of circuit breakers.
- The LSP uses current transformers (CTs) to measure overall power flows. Correct placement of these CTs is crucial. See pg. 23.
- Selecting the correct maximum current setting and controlled loads is very important. This procedure is detailed in the Certified Installer training. The training material can be reviewed at any time after completing the training.



Need help? For system design and installation assistance please contact Lumin by e-mail at support@luminsmart.com or by phone at 1-888-421-0616 (North America).

INSTALLATION

Items in the Box

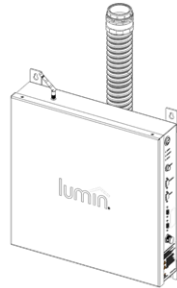

1 LSP with Conduit, Conduit Bushings & Wire Whips Attached

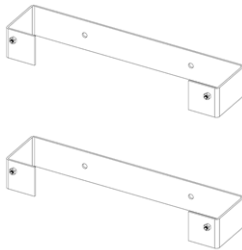

2 Mounting Brackets
(Surface-mounted installation)

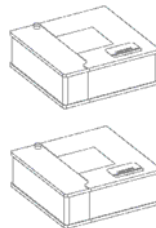

1 Pair of 200A Current Transformers
(Contact Lumin for a second pair when backfed solar PV is present)

NOTE: Additional items include an antenna, installation hardware, *Lumin Identifier Sticker Sheet*, *Current Setting* sticker, and an *LSP Circuit Label & CT Table*.

Required Materials (Not Included)



Wire splice connectors



Pen or marker

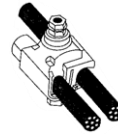

Supply-side/line-side tap
(Optional)



Cable ties (Optional)



Electrical tape (Optional)

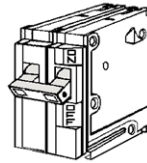

Dual-pole breaker: 15 to 20 amps
(Optional)

NOTE: Additional supplies may be required depending on the existing electrical panel installation. A dual-pole breaker of 15 to 20 amps may be required to power the LSP. Appropriately rated breakers may be double-tapped depending on local electrical codes. See pg. 17 for more details.

Required Tools



Drill

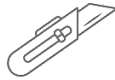

Utility knife

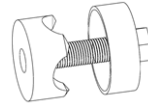

**Knockout punch or hole saw for
2" conduit
(2-1/2" hole size)**

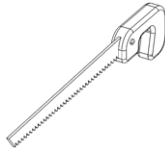

Drywall saw (optional)



Multimeter

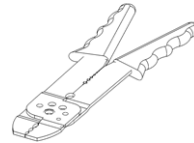

Wire stripper

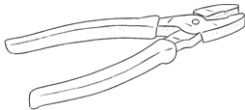

Pliers



Stud-finder (optional)



Fish tape (optional)

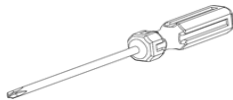

Phillips screwdriver

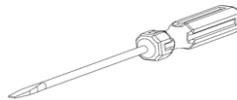

Flathead screwdriver

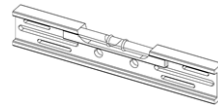

Level (optional)

NOTE: A multimeter may be required for determining current transformer placement (see pg. 25).

Hardware Installation Overview

- STEP 1. Turn Off Main Breaker and Remove Electrical Panel Cover
- STEP 2. (Flush-Mount Only) Cut and Remove Drywall
- STEP 3. Knock Out or Punch One Hole for 2" Conduit Fitting
- STEP 4. Measure and Mark Hole Locations for Mounting
- STEP 5. (Surface-mount Only) Secure Mounting Brackets to Wall
- STEP 6. Attach LSP Antenna and Guide LSP Wire Whip into Electrical Panel
- STEP 7. Secure LSP to Wall/Bracket and Electrical Panel
- STEP 8. Connect LSP Equipment Grounding Conductor (EGC) to Ground Bar
- STEP 9. Identify A-Row and B-Row Breakers
- STEP 10. Connect LSP Power Circuit and Label Breaker
- STEP 11. Select Circuit Breaker to Connect to LSP and Disconnect Load Wire
- STEP 12. Connect LSP Wire Labeled "Line 1 Breaker" to Circuit Breaker
- STEP 13. Connect LSP Wire Labeled "Line 1 Load" to Load
- STEP 14. Record Circuit Name and Breaker Row (A/B) With Corresponding LSP Line Number
- STEP 15. Repeat Steps 11-14 Until All LSP Line # Wires Are Connected
- STEP 16. Determine Placement of Current Transformers (CTs)
- STEP 17. Phase Conductors Monitored by Current Transformers
- STEP 18. Test for Crossover before Current Transformer Placement
- STEP 19. Connect Current Transformers
- STEP 20. Record the Placement of Current Transformers
- STEP 21. Cap the Grid Detection Circuit Wires
- STEP 22. Replace Electrical Panel Cover and Turn On Main Breaker
- STEP 23. LSP Configuration
- STEP 24. Complete Current Limiting Label
- STEP 25. Apply Labels

Hardware Installation Steps

STEP 1. Turn Off Main Breaker and Remove Electrical Panel Cover

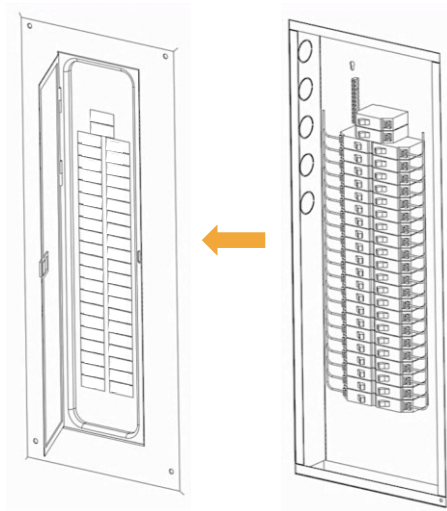

WARNING: HIGH VOLTAGE. ENSURE MAIN BREAKER IS OFF. MAIN SERVICE LINES ARE ALWAYS LIVE.
AVERTISSEMENT: HAUTE TENSION. ASSUREZ-VOUS QUE LE DISJONCTEUR PRINCIPAL EST ÉTEINT. LES CONDUCTEURS DE SERVICE PRINCIPAUX SONT TOUJOURS SOUS TENSION.

Tools: Screwdriver

STEP 2. (Flush-Mount Only) Cut and Remove Drywall

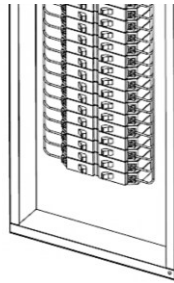

Drywall Cutout Option A

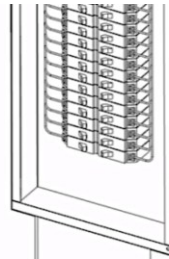

Drywall Cutout Option B



WARNING: HIGH VOLTAGE. ENSURE MAIN BREAKER IS OFF. ENSURE CUTTING PATH IS FREE OF ELECTRICAL CONDUCTORS.

AVERTISSEMENT: HAUTE TENSION. ASSUREZ-VOUS QUE LE DISJONCTEUR PRINCIPAL EST ÉTEINT. ASSUREZ-VOUS QUE LE CHEMIN DE COUPE EST EXEMPT DE CONDUCTEURS ÉLECTRIQUES.

Tools: Tape measure, level (optional), stud finder (optional), and drywall saw or suitable alternative

NOTE: Cut and remove enough wall material to accommodate the LSP's wire whips. Consider drywall cutout "Option B" if additional space is required to accommodate the LSP's wire whips and properly access the electrical panel for Step 3.

STEP 3. Knock Out or Punch One Hole for 2" Conduit Fitting

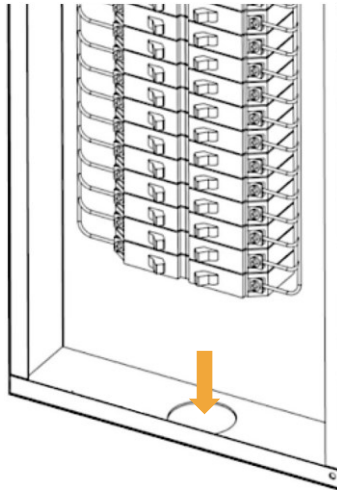

 **WARNING: HIGH VOLTAGE. ENSURE MAIN BREAKER IS OFF. MAIN SERVICE LINES ARE ALWAYS LIVE.**
AVERTISSEMENT: HAUTE TENSION. ASSUREZ-VOUS QUE LE DISJONCTEUR PRINCIPAL EST ÉTEINT. LES CONDUCTEURS DE SERVICE PRINCIPAUX SONT TOUJOURS SOUS TENSION.

Tools: Screwdriver, pliers, drill (optional), and knockout punch (optional)

NOTE: Hole location in electrical panel may vary depending on spacing constraints. The installer should choose a location that avoids existing obstructions and provides adequate clearance for routing of the LSP wire whips. The hole location can be below as shown, above, or to either side of the electrical panel as appropriate. Use of existing pre-stamped 2" knockouts are acceptable provided there is sufficient clearance. Otherwise, a 2" knockout punch (2-1/2" hole) will be required to attach the LSP conduit.

STEP 4. Measure and Mark Hole Locations for Mounting

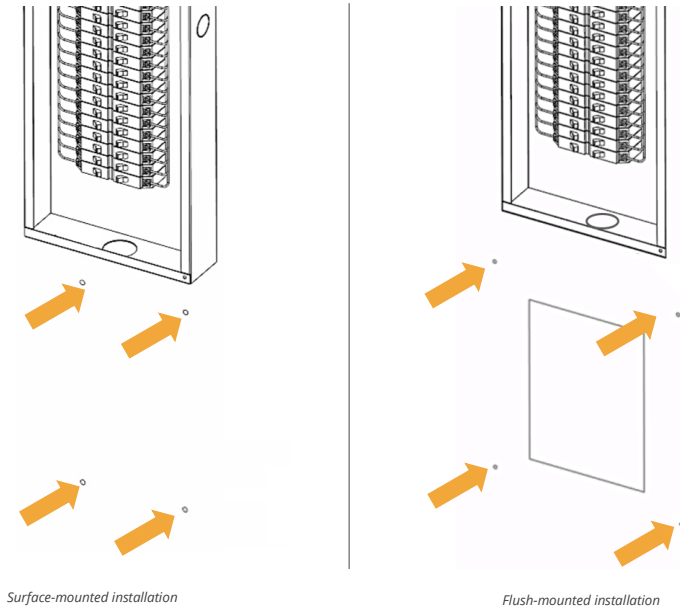

Tools: Tape measure, marker, stud-finder (optional), and level (optional)

NOTE: Mark the applicable hole locations for the installation type (flush-mount vs. surface-mount with mounting brackets). Exact hole locations may vary depending on existing conditions. Qty 4 holes are required for the LSP.

NOTE: Alternative Installation Method: Installers may find it easier to route the wire whip into the electrical panel and attach the conduit to the electrical panel before determining the mounting hole locations. See Steps 6 and 7 for more details.

STEP 5. (Surface-mount Only) Secure Mounting Brackets to Wall

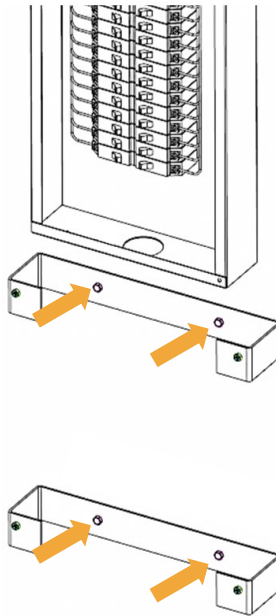

Tools: Drill, stud-finder (optional), screws (x4), and washers (x4)

NOTE: Ensure all screws are securely threaded into studs or suitable anchor systems.

STEP 6. Attach LSP Antenna and Guide LSP Wire Whip into Electrical Panel

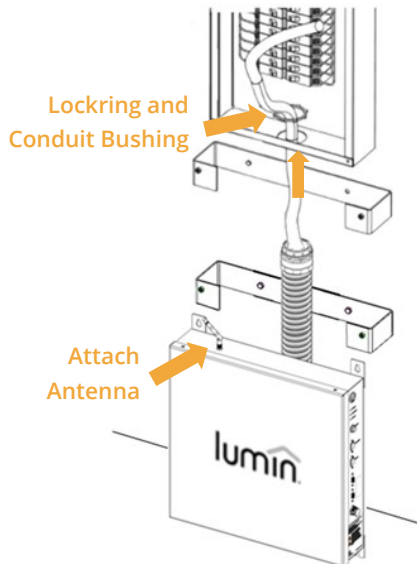

Surface-mounted installation

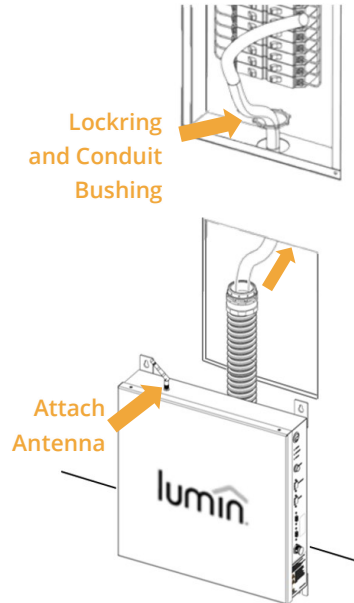

Flush-mounted installation



WARNING: HIGH VOLTAGE. ENSURE MAIN BREAKER IS OFF. MAIN SERVICE LINES ARE ALWAYS LIVE.
AVERTISSEMENT: HAUTE TENSION. ASSUREZ-VOUS QUE LE DISJONCTEUR PRINCIPAL EST ÉTEINT. LES CONDUCTEURS DE SERVICE PRINCIPAUX SONT TOUJOURS SOUS TENSION.

NOTE: Attach the antenna provided with the LSP and then guide the wire whip through the hole in the electrical panel. Remove the conduit bushing and lockring before guiding the wire whip through the hole.

STEP 7. Secure LSP to Wall/Bracket and Electrical Panel

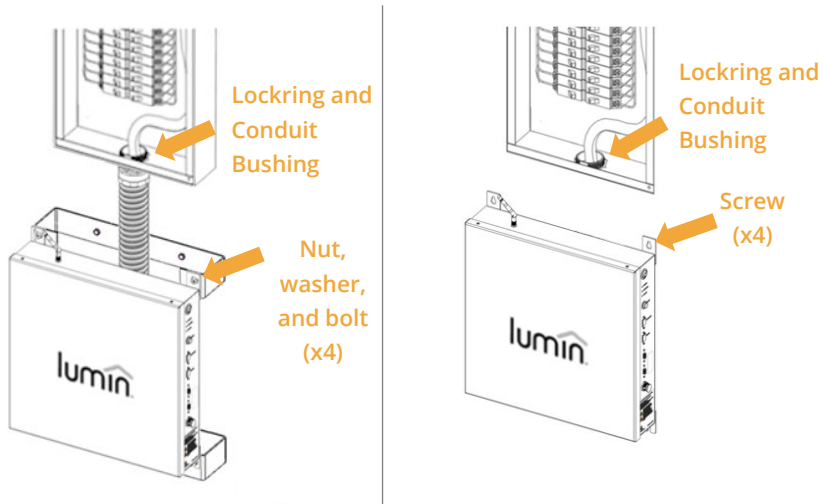

Surface-mounted installation

Flush-mounted installation



WARNING: HIGH VOLTAGE. ENSURE MAIN BREAKER IS OFF. MAIN SERVICE LINES ARE ALWAYS LIVE.
AVERTISSEMENT: HAUTE TENSION. ASSUREZ-VOUS QUE LE DISJONCTEUR PRINCIPAL EST ÉTEINT. LES CONDUCTEURS DE SERVICE PRINCIPAUX SONT TOUJOURS SOUS TENSION.

Tools: LSP: Drill, screws (x4), washers (x4), and nuts (x4); surface-mount only)

NOTE: Lift the LSP to align with the mounting holes and secure it directly to the wall (flush-mount installation — ensure all screws are securely threaded into studs or suitable anchor systems) or mounting brackets (surface-mount installation) utilizing the hardware provided. Secure the LSP to the electrical panel with the 2" locking and conduit bushing provided.

STEP 8. Connect LSP Equipment Grounding Conductor (EGC) to Ground Bar

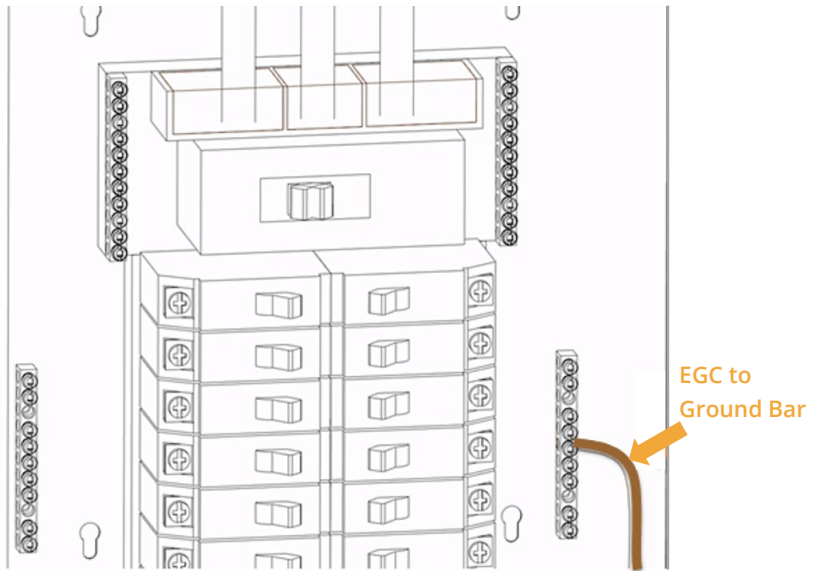

WARNING: HIGH VOLTAGE. ENSURE MAIN BREAKER IS OFF. MAIN SERVICE LINES ARE ALWAYS LIVE. GROUND WIRE MUST BE INSTALLED FOR SAFETY.
AVERTISSEMENT: HAUTE TENSION. ASSUREZ-VOUS QUE LE DISJONCTEUR PRINCIPAL EST ÉTEINT. LES CONDUCTEURS DE SERVICE PRINCIPAUX SONT TOUJOURS SOUS TENSION. UN FIL DE TERRE DOIT ÊTRE INSTALLÉ POUR LA SÉCURITÉ.

Tools: Screwdriver and pliers (optional)

NOTE: Connect the EGC (bare copper wire) from the LSP to the existing ground bar in the electrical panel (exact location of ground bar may vary).

STEP 9. Identify A-Row and B-Row Breakers

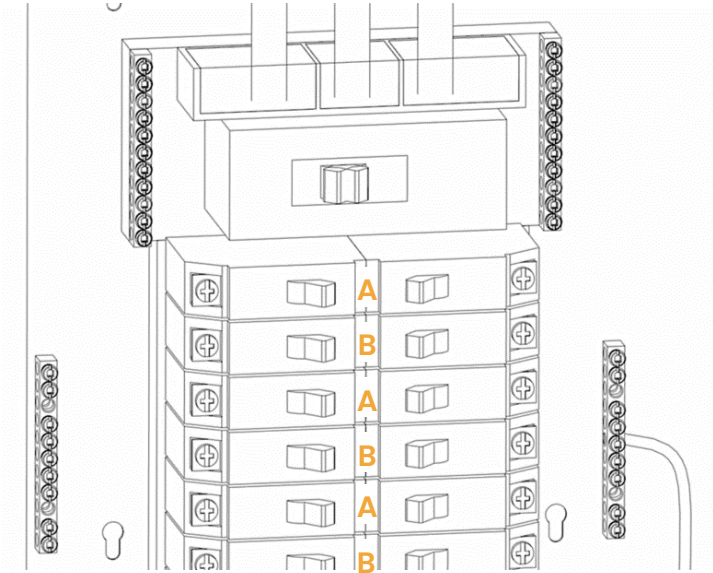

NOTE: For purposes of Lumin installation, the top row of breakers will *always* be classified as “A”. The second row of standard breakers will be “B”. The alternating A-B-A-B pattern continues down the rows of breakers. **Exception:** All breaker rows are designated “A” in panels with two-wire single-phase power rather than three-wire single-phase (split phase).

NOTE: If the load center contains tandem or “skinny” breakers, there will be two breakers in a standard breaker space. Thus, the top-to-bottom breaker panel will be A-A-B-B-A-A-B-B.

STEP 10. Connect LSP Power Circuit and Label Breaker

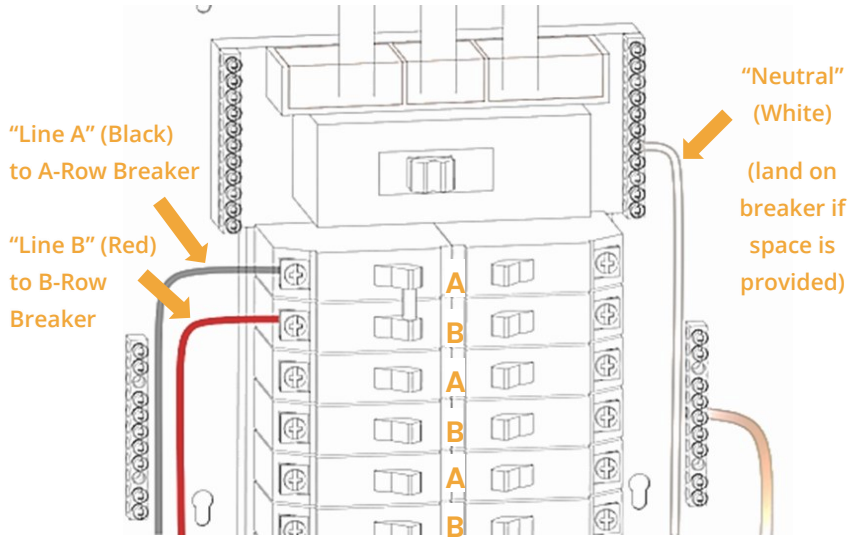

WARNING: HIGH VOLTAGE. ENSURE MAIN BREAKER IS OFF. MAIN SERVICE LINES ARE ALWAYS LIVE.
AVERTISSEMENT: HAUTE TENSION. ASSUREZ-VOUS QUE LE DISJONCTEUR PRINCIPAL EST ÉTEINT. LES CONDUCTEURS DE SERVICE PRINCIPAUX SONT TOUJOURS SOUS TENSION.

Tools: Screwdriver, pliers, and wire stripper

NOTE: Connect the LSP wires as pictured to the existing neutral bar and a double-pole 15- to 20-amp breaker, landing Line A (black wire) on an A Leg (odd-row breaker) terminal and Line B (red wire) on a B Leg (even-row breaker) terminal. Mark the breaker with a clearly identifying label (ex. "Lumin Smart Panel Power"). **If using a GFCI breaker, ensure that the Lumin neutral is connected to the breaker and the breaker neutral is terminated on the neutral bar.** Do not double-tap breakers unless they are appropriately rated.

STEP 11. Select Circuit Breaker to Connect to LSP and Disconnect Load Wire

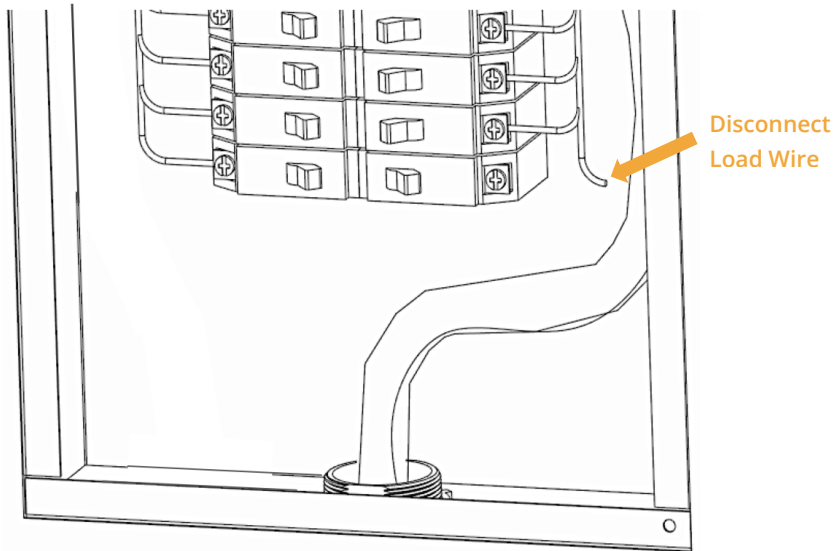

⚠ WARNING: HIGH VOLTAGE. ENSURE MAIN BREAKER IS OFF. MAIN SERVICE LINES ARE ALWAYS LIVE.
AVERTISSEMENT: HAUTE TENSION. ASSUREZ-VOUS QUE LE DISJONCTEUR PRINCIPAL EST ÉTEINT. LES CONDUCTEURS DE SERVICE PRINCIPAUX SONT TOUJOURS SOUS TENSION.

Tools: Screwdriver

NOTE: Breaker labels should be marked using the provided stickers to indicate that the load is controlled by the LSP. **In typical applications, do not connect breakers that power the router(s)/modem(s) that provide the LSP Internet connection.**

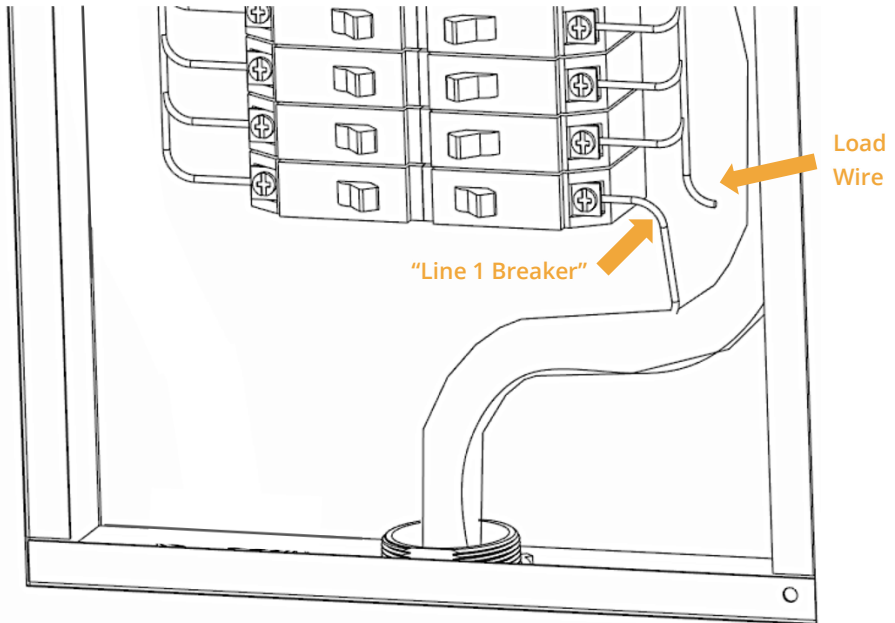
STEP 12. Connect LSP Wire Labeled “Line 1 Breaker” to Circuit Breaker

WARNING: HIGH VOLTAGE. ENSURE MAIN BREAKER IS OFF. MAIN SERVICE LINES ARE ALWAYS LIVE.
AVERTISSEMENT: HAUTE TENSION. ASSUREZ-VOUS QUE LE DISJONCTEUR PRINCIPAL EST ÉTEINT. LES CONDUCTEURS DE SERVICE PRINCIPAUX SONT TOUJOURS SOUS TENSION.

Tools: Screwdriver and wire stripper

NOTE: All LSP wires labeled “Line # Breaker” must connect to a breaker or be safely terminated with a wire connector/cap. Lines 1-6 (6 AWG wire) can connect to circuit breakers rated up to 60 amps and lines 7-12 (10 AWG wire) can connect to circuit breakers rated up to 30 amps (see pg. 35).

STEP 13. Connect LSP Wire Labeled "Line 1 Load" to Load

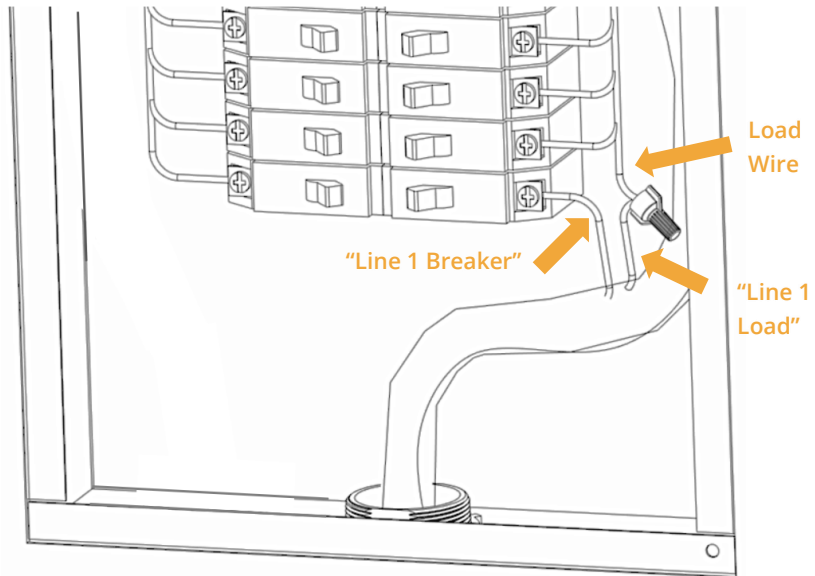

WARNING: HIGH VOLTAGE. ENSURE MAIN BREAKER IS OFF. MAIN SERVICE LINES ARE ALWAYS LIVE.
AVERTISSEMENT: HAUTE TENSION. ASSUREZ-VOUS QUE LE DISJONCTEUR PRINCIPAL EST ÉTEINT. LES CONDUCTEURS DE SERVICE PRINCIPAUX SONT TOUJOURS SOUS TENSION.

Tools: Wire stripper and wire splice connector

NOTE: All LSP wires labeled "Line # Load" must connect to a load wire via a wire splice connector (ensuring a tight connection) or be safely terminated with a wire connector. The LSP wire line number must match the line number used in the previous step (e.g., "Line 3 Breaker" connects to a breaker and "Line 3 Load" connects to that breaker's load).

STEP 14. Record Circuit Name and Breaker Row (A/B) With Corresponding LSP Line Number

LSP LINE #	BREAKER ROW (circle one)	CIRCUIT BREAKER LABEL/NAME	LSP LINE #	BREAKER ROW (circle one)	CIRCUIT BREAKER LABEL/NAME
1	A	<i>Pool Pump</i> Single-pole circuit	7	A	
	B				
2	A	<i>Range</i> Double-pole circuit	8	A	
	B				
3	A	<i>Range</i>	9	A	
	B				
4	A		10	A	
	B				
5	A		11	A	
	B				
6	A		12	A	
	B				
		CURRENT TRANSFORMER (CT)	CURRENT TRANSFORMER (CT)		
Line A/B CTs			Aux. A/B CTs (Optional)		

NOTE: Record the circuit label/name and breaker row (A or B) with the corresponding LSP line number in the *LSP Circuit Label & CT Table* provided with the LSP (e.g., LSP Line 1 is landed on a B-row breaker that protects the pool pump. Record “Pool Pump” next to LSP Line 1 and circle Breaker Row “B”). Double-pole circuit breakers will require two LSP wire sets, and thus two LSP line numbers.

STEP 15. Repeat Steps 11-14 Until All LSP Line # Wires Are Connected

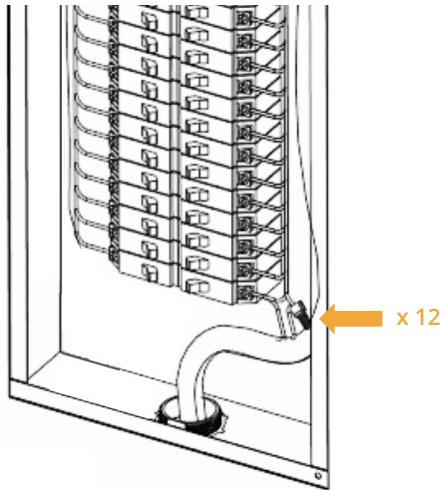

WARNING: HIGH VOLTAGE.
AVERTISSEMENT: HAUTE TENSION.

Tools: Screwdriver, wire stripper, and wire splice connectors

NOTE: All LSP wires labeled “Breaker” must connect to a breaker. Lines 1-6 (6 AWG wire) can connect to circuit breakers rated up to 60 A and lines 7-12 (10 AWG wire) can connect to circuit breakers rated up to 30 A (see pg. 35).

NOTE: The LSP can connect to up to 12 single-pole (or six double-pole) circuit breakers. Each hot leg of a double-pole circuit must be connected to its own numbered Lumin wire set (e.g., LSP controls a clothes dryer. Dryer Leg "A" is connected to LSP Line 3. Dryer Leg "B" is connected to LSP Line 4).

NOTE: Controlling the circuit that powers the Internet/LAN equipment is not recommended; app access to the LSP will be lost when this circuit is switched off.

STEP 16. Determine Placement of Current Transformers (CTs)

DO NOT INSTALL CTS UNTIL PROPER LOCATION AND PHASING HAVE BEEN DETERMINED.

Each LSP is supplied with one set of two (2) 200-amp current transformers (CTs). The LSP is equipped with leads for these main CTs (labeled “Line A CT” and “Line B CT”) as well as leads for an optional set of auxiliary CTs, available for purchase from Lumin and only used when solar is backed into the electrical panel as shown below. When auxiliary CTs are not used, the unused “aux” leads should be coiled neatly in the electrical panel. For any situation other than the two shown below, contact Lumin support for CT placement advice.

Note: Main CTs are not required if using Lumin in a “branch limiting” configuration, where only a portion of the home’s circuits need to be monitored and controlled. See Lumin Certified Installer training for more details about this configuration.

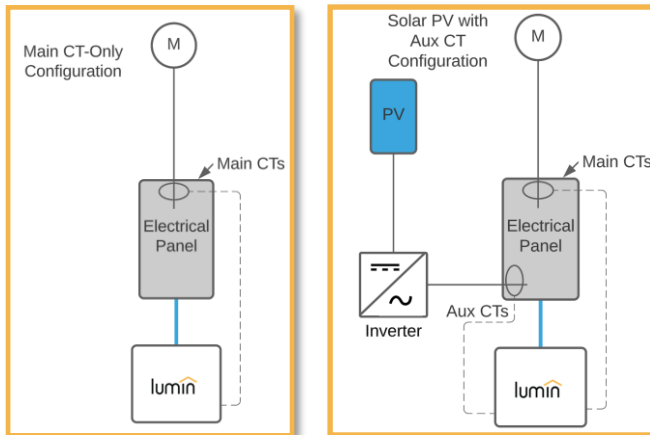

Figure A – CT Configurations

STEP 17. Phase Conductors Monitored by Current Transformers

REMANDER: In a Lumin installation, the top* row of breakers in an electrical panel is **always** designated "A." Whichever conductor supplies breaker Row A will be designated "Line A."

NOTE: Lumin CTs are designated either "Line A" or "Line B". Placing them on the incorrect leg of a circuit will result in erroneous consumption data.

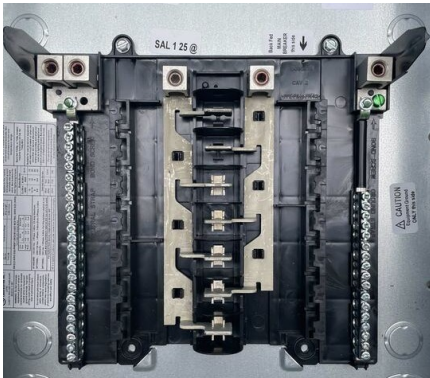

Figure B - Typical Main-Lug-Only Electrical Panel Busing

If the panel is a main-lug-only type, as shown in Figure B (no main circuit breaker), then the feeder on the left will be Lumin Leg "A".

If the panel includes a main circuit breaker, note that the main breaker may contain crossover busing, with the result that the feeder on the left feeds the right-side bus bar and the feeder on the right feeds the left-side bus bar. To identify A/B feeders when a main breaker is present, consult the following page.

* All descriptions assume a top-fed electrical panel.

STEP 18. Test for Crossover before Current Transformer Placement

REMINDER: In a Lumin installation, the top* row of breakers in an electrical panel is *always* designated “A”. Whichever conductor supplies breaker Row A will be designated “Line A.”

To determine which service conductor or feeder is Line A and which is Line B when a main circuit breaker is present, switch the main breaker to the closed/on position. Test for AC voltage between the left lug and the left bus bar*. If the bus bar is not accessible, test between the left lug and the terminal on the top left circuit breaker. See Figure C.

If VAC between these points is ≈ 240 , the main breaker contains crossover bussing. Place CT A on the right and CT B on the left. If VAC between these points ≈ 0 , the main breaker is a standard type (no internal bussing).

Switch the main breaker to the open/off position once the voltage readings are complete.

Tools: Multimeter

* All descriptions assume a top-fed electrical panel.

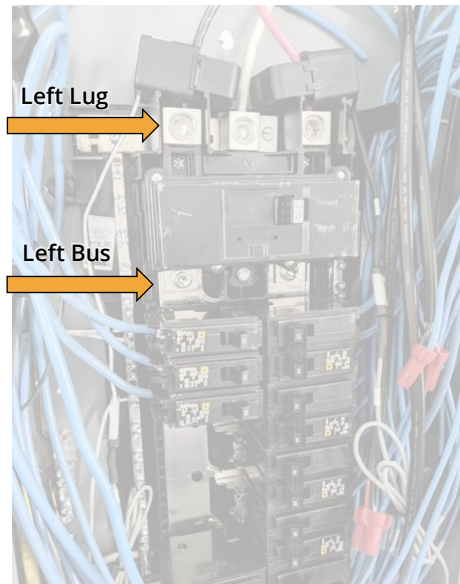

Figure C – Typical Main Breaker Electrical Panel



WARNING: HIGH VOLTAGE.

AVERTISSEMENT: HAUTE TENSION.

STEP 19. Connect Current Transformers

Prior to installation, measure the CT leads' routing path(s) in the electrical panel. Local electrical codes may require securing CT wiring at regular intervals. If the provided leads are not long enough, fashion CT wire extensions in the field. Scan the adjacent code for information on the proper extension procedures.



Connect CTs to their corresponding CT leads coming from the Lumin conduit **before** clamping the CTs around the conductors to be measured. The CT marked with "A" should attach to Leg A and the CT marked with "B" should attach to Leg B. Ensure the sticker on the CT reading "This side toward grid" is facing toward the grid/utility meter.

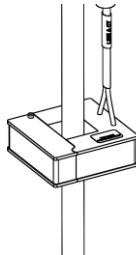

WARNING: HIGH VOLTAGE. MAIN SERVICE LINES ARE ALWAYS LIVE.

AVERTISSEMENT: HAUTE TENSION. LES CONDUCTEURS DE SERVICE PRINCIPAUX SONT TOUJOURS SOUS TENSION.

CAUTION: A CT SHOULD NEVER BE LEFT CLAMPED ON A CONDUCTOR WHEN THE CT WIRING IS DISCONNECTED. SATURATION AND DESTRUCTION OF THE CT CORE MAY RESULT. CONNECT CT WIRING BEFORE CLAMPING. UNCLAMP BEFORE DISCONNECTING CT WIRING.

ATTENTION: UN TRANSFORMATEUR DE COURANT NE DOIT JAMAIS ÊTRE LAISSÉ SERRÉ SUR UN CONDUCTEUR LORSQUE LES FILS DU TRANSFORMATEUR DE COURANT SONT DÉCONNECTÉS. LA SATURATION ET LA DESTRUCTION DU NOYAU PEUVENT EN RÉSULTER. CONNECTER LES CÂBLES DU TRANSFORMATEUR DE COURANT AU LSP AVANT L'INSTALLATION. DÉINSTALLER LE TRANSFORMATEUR DE COURANT AVANT DE DÉBRANCHER SON CÂBLE.

STEP 20. Record the Placement of Current Transformers

LSP LINE #	BREAKER ROW (circle one)	CIRCUIT BREAKER LABEL/NAME	LSP LINE #	BREAKER ROW (circle one)	CIRCUIT BREAKER LABEL/NAME
1	A		7	A	
	B			B	
2	A		8	A	
	B			B	
3	A		9	A	
	B			B	
4	A		10	A	
	B			B	
5	A		11	A	
	B			B	
6	A		12	A	
	B			B	
		CURRENT TRANSFORMER (CT)			CURRENT TRANSFORMER (CT)
Line A/B CTs		<i>Ex. Main Service Lines</i>	Aux. A/B CTs (Optional)		<i>Ex. Solar Output</i>

In the *LSP Circuit Label & CT Table*, record the location of the CTs. For example, record “Main Service Lines” next to “Line A/B CTs” if the CTs are clamped around the service lines. If auxiliary CTs are not used, leave the “Aux A/B CT” space blank.

STEP 21. Cap the Grid Detection Circuit Wires



Use wire nuts to cap off wires labeled "Grid Line" and "Grid Neutral" and coil these conductors in the bottom of the panel. These wires are not used in this configuration of the Lumin Smart Panel.

STEP 22. Replace Electrical Panel Cover and Turn On Main Breaker

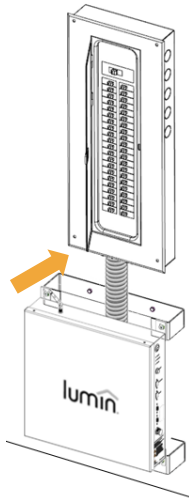

Surface-mounted installation

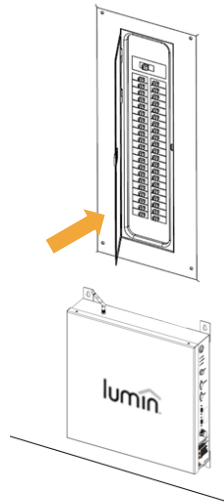

Flush-mounted installation

Tools: Screwdriver

NOTE: Please make any necessary drywall repairs (if applicable) and clean up the area around the circuit breaker panel once the LSP installation is completed. Make sure the LSP's antenna is securely attached prior to powering on the device from the electrical panel. The LSP will turn on when the Lumin Power Circuit (the breaker from **Step 10**) is energized. Note that there is a rectangular cover over the LSP power switch. This switch does not need to be accessed during a typical installation and per the National Electric Code, the cover must remain in place during operation to prevent the end user from accessing the power switch.

STEP 23. LSP Configuration

Configuration and Account Setup

Please note that the configuration and account setup process may change as the Lumin Energy app is updated. The steps below are a generalized version of the commissioning process. To view more detailed information on this process, refer to our Knowledge Base by going to luminpanelguard.freshdesk.com or scanning the code.



1. After completing the hardware installation, ensure the blue and green indicator lights are blinking in unison, indicating that the LSP is ready for commissioning.
2. If feasible, make an Ethernet connection between the Lumin Smart Panel's Ethernet port and a LAN port on the location's router. This Ethernet connection is more reliable than a WiFi connection and is not affected by replacing the router or resetting the WiFi password.
3. Download the Lumin Energy mobile app (<https://get.lumin.energy>). In the Apple App Store or Google Play Store, search for "Lumin Energy".
4. Log in with an existing account or create a new account. **You must complete Certified Installer training before setting up a system in the app.**
5. Select "Get Started" and follow the in-app instructions to set up your Lumin Smart Panel **(completed LSP Circuit Label & CT Table required).**

Need help? For account setup assistance or troubleshooting, please call 1-888-421-0616 (North America) or e-mail support@luminsmart.com.

STEP 24. Complete Current Limiting Label

NOTE: Record the maximum current setting entered into the Lumin Energy app (maximum 80% of main breaker rating).

The maximum current setting is normally not changed after initial installation. It can only be changed by a user of the system who has completed Lumin Certified Installer training. Changes to this setting can only be entered locally, while connected to the same network as the Lumin Smart Panel.

Complete the rest of the current limiting label, including the list of controlled loads/circuits connected to the Lumin Smart Panel.

Need help? For account setup assistance or troubleshooting, please call 1-888-421-0616 (North America) or e-mail support@luminsmart.com.

The setting for the EMS current limiting feature **shall not be bypassed**

COMPANY NAME:

LUMIN CERTIFIED INSTALLER:

MAXIMUM CURRENT SETTING:

DATE OF CALCULATION AND SETTING:

IDENTIFY CONTROLLED LOADS:

1

2

3

4

5

6

7

8

9

10

11

12

lumin



STEP 25. Apply Labels

WARNING: ELECTRICAL CODES MAY REQUIRE ADDITIONAL LABELING.
AVERTISSEMENT: LES CODES ELECTRIQUES PEUVENT NECESSITER UN ETIQUETAGE SUPPLEMENTAIRE.

Tools: Screwdriver

NOTE: The National Electrical Code requires additional labeling for energy management systems such as the LSP. The provided installation materials include labels to identify the LSP-managed circuits in the electrical panel, LSP electrical conduit/raceway, and informational QR code labels. Apply label stickers as shown and as detailed on the provided sticker sheets. Electrical code requirements may vary depending on the installation location.

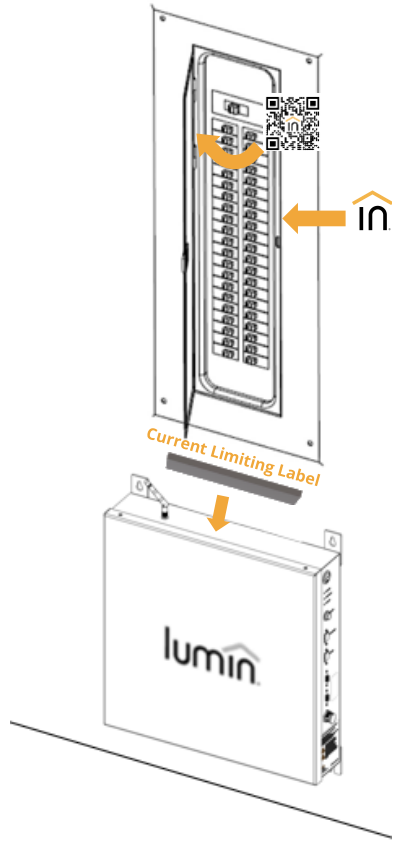

TROUBLESHOOTING AND REPAIRS

End User

If the LSP is not functioning as expected, ensure that the Internet service is available, antenna/Ethernet connection is secure, and breakers are switched on. See Operational Information (pg. 34) on how to read the LSP indicators for Internet connectivity status. It is best to obtain assistance from a qualified installer for further troubleshooting of hardware issues. The installer's familiarity with Lumin products and ability to perform electrical work will help resolve issues effectively. Alternatively, contact Lumin directly for assistance.

Qualified Installer

Observe all safety precautions listed on Page 2. Never use the LSP to de-energize circuits to perform electrical work. The LSP is not designed as a safety disconnecting means; lock-out/tag-out is not possible. If not properly connected the app may falsely indicate that a circuit is de-energized, so always assume that LSP circuits are live.

Lumin Certified Installer training is required before Lumin will authorize work on an existing LSP. Case-specific authorization and instruction will be provided by Lumin if applicable. Do not open cover or attempt repairs otherwise — even with breakers off hazardous voltages may be present. **Neither the LSP power circuit breaker nor the LSP power switch de-energize the internal product components.** The main breaker and all other power sources must be de-energized to ensure the LSP is safe to work on. *Fuses: LSP Power – non-replaceable 2.5 A; GDC – 1 A, slow blow.*



DANGER: HAZARDOUS VOLTAGES PRESENT DURING INSTALLATION AND SERVICING. DO NOT OPEN LSP COVER, INSPECT INSTALLATION WIRING, OR ATTEMPT REPAIRS WITHOUT REQUIRED QUALIFICATIONS AND LUMIN AUTHORIZATION. ALWAYS DISCONNECT ELECTRICAL SUPPLY BEFORE PERFORMING REPAIRS.



DANGER: TENSIONS DANGEREUSES PRÉSENTES LORS L'INSTALLATION ET L'ENTRETIEN. NE PAS OUVRIR LE COUVERCLE DU LSP, INSPECTER LE CÂBLAGE D'INSTALLATION OU ESSAYER DE RÉPARER SANS QUALIFICATIONS REQUISES ET AUTORISATION DE LUMIN. TOUJOURS DÉBRANCHER L'ALIMENTATION ÉLECTRIQUE AVANT D'EFFECTUER DES RÉPARATIONS.

OPERATIONAL INFORMATION

LED Indicator	Off	On
Red "Power"	Power Off or Not Present	Power On

LED Indicator	Off	Both Blinking	Just One Blinking	Both Solid
Green "Network"	Lumin Server Disconnected	Setup Mode. WiFi connectivity is disabled. Press and release "Setup" button to exit	(When blue is solid) Lumin server error	Fully connected via WiFi
Blue "Online"	No Internet Connection via WiFi		Attempting to connect to the Internet	

NOTE: Simultaneous blue and green blinking lights indicate that the LSP is in Setup Mode. This is the required mode for initial setup and commissioning. However, the LSP does not connect to the Internet via WiFi in this mode. If both lights are seen blinking during normal operation, it is likely that the "Setup" button was pressed, taking the LSP offline. In most instances, an additional press-and-release of the "Setup" button will bring the LSP back online. It may take about 45 seconds to restore the connection and display two solid unblinking indicator lights.

NOTE: During an Internet outage, local connection can be made between an LSP and user's mobile device as long as the device and the LSP are connected to the same network. Ensure that the LSP is not in Setup Mode and that WiFi connectivity is enabled on the mobile device.



Need help? For additional support documentation, visit luminpanelguard.freshdesk.com or scan the code at right:

PRODUCT SPECIFICATIONS

INSTALLATION	
Type	Wall-Mount; Indoor Only
Installer Qualification	Local Electrical Codes and Lumin Certified Installer
Typical Time Required	1.5-4 Hours
Temperature	0°C to 60°C (32°F to 140°F)
Humidity	< 80% RH (Non-Condensing)
Altitude	< 3000 m
Pollution Level	Degree 2
Dimensions	44.6 cm × 44.6 cm × 10.1 cm (17.5 in × 17.5 in × 4.0 in)
Weight	12 kg (27 lb)
Conductor Length	All Extend 76 cm (30 in) Beyond Conduit End
Additional Units	One (1) Lumin Smart Panel per electrical panel for service upsize avoidance
CONNECTIVITY & SECURITY	
Connection Options	WiFi or Ethernet
Internet Bandwidth	Approx. 0.02 Mbps
WiFi Protocols	802.11 b/g/n, 2.4 GHz
WiFi Encryption	WPA and WPA2 Methods
Ethernet Port	1×RJ-45 (10/100/1000 Mbps)
IP Addressing	Dynamic (DHCP)
Cryptographic System	TLS 1.2 (Minimum)
Firewall Outbound Access Required	Ports 53, 123, 443-444, and 50050-50059
USER ACCESS	
Local Network	Live Data and Controls
Applications	iOS, Android, and Web
Data	1-Second Granularity (Averaged from 16 kHz)
Load Controls	Manually/Directly, Automated Schedules, and Automated Modes

ELECTRICAL SYSTEM	
AC Voltage	120/240 VAC Split-Phase, 50-60Hz
Supply Breaker Rating	15-20 A (non-GFCI)
Supply Amperage	0.4 A (Maximum)
Standby Power	6 W
Voltage Fluctuations	±10% from Nominal
Overvoltage	Category III (Building Wiring)
MANAGED LOADS	
Max. Load Breaker Ratings up to 50 °C	60 A per Line × 6 Lines and 30 A per Line × 6 Lines
Load Breaker Ratings at 50-60 °C	50 A per Line × 6 Lines and 20 A per Line × 6 Lines
Breaker Types	Single Pole (1 Line) and Dual Pole (2 Lines)
MEASUREMENT	
Accuracy	±0.5% of Load
Monitoring Type	Separate Measurement of Lines (Including Dual-Pole)
Split-Phase Voltage	Separate Line-to-Neutral Potential Measurement
Current Transformers	2 Split-Core 200 A Included; Up to 2 Additional Available
Measurement Category	Loads: CAT III (Mains Distr.) GDC: CAT IV (Mains Source)
SUPPORT & COMPLIANCE	
Warranty	10-Year Limited
Compatible Equipment	All Makes/Models/Brands of Electrical Panels and Breakers
Safety Compliance	MET Listing E115439; UL 916, CSA C22.2 No.205, and UL/CSA 61010
Radiofrequency Compliance	47 CFR 15 (FCC) RSS-Gen and RSP-100 (ISED)



LIMITED WARRANTY FOR LUMIN SMART PANEL

This Limited Warranty gives you specific legal rights and you may also have other rights, which vary from state to state. We warrant that during the warranty period, the product will be free from defects in materials and workmanship. To the maximum extent allowable under applicable law, this Limited Warranty is offered in lieu of, and we fully disclaim, any and all implied warranties and any implied remedies, including without limitation the warranties of merchantability and fitness for a particular purpose. Some states do not allow disclaimers of certain implied warranties or limitations on how long certain implied warranties last, so the above limitations may not apply to you. To the maximum extent allowable under applicable law, our responsibility for defective goods is limited to repair, replacement, or refund as described below in this warranty statement.

Who May Use This Warranty? Coulomb Inc. (d/b/a Lumin), a Delaware corporation located at address 501 Locust Ave, Floor 1, Suite 2, Charlottesville, VA 22902 ("we") extends this limited warranty only to the consumer who originally activated the product and connected it to a Lumin Account (through luminsmart.com) and to any subsequent owner or other transferee of the product ("you").

What Does This Warranty Cover? This limited warranty covers defects in materials and workmanship of the Lumin Smart Panel (the "product") for the Warranty Period as defined below.

What Does This Warranty Not Cover? This limited warranty does not cover any damage due to: (a) transportation; (b) storage; (c) improper installation; (d) improper use; (e) failure to follow the product instructions; (f) failure to adhere to the product's technical specifications, including the product's environmental and electrical ratings; (g) modifications; (h) unauthorized opening of the product's cover; (i) tampering with the product's internal components; (j) unauthorized repair; (k) normal wear and tear; (l) external causes such as accidents, abuse, flooding, lightning strikes, storms, or other actions or events beyond our reasonable control; or (m) user error, including acts or omissions of any end user or any administrator (other than where Lumin acts as sole administrator). This limited warranty also does not apply to the software, mobile applications, technology and services provided by Lumin which enable you to remotely access and view data that is collected, stored and transmitted by the product concerning electricity consumption and/or to remotely control electrical circuits which the product is connected to (the "Lumin Service"). Use of the Lumin Service is subject to and governed by the terms of the Lumin Service User Agreement, a copy of which can be accessed at luminsmart.com/consent-documentation/. The warranties expressly set forth in the Lumin Service User Agreement are the sole and exclusive warranties that apply to the Lumin Services.

What Is the Period of Coverage? The "Warranty Period" for this limited warranty starts on the date the product is first activated and connected to a Lumin Account (through luminsmart.com) and lasts (a) for two years for the product's sensor boards and the processor board, including the individual components that make up the sensor boards and processor board, and (b) for ten years for all other components of the product. The Warranty Period is not extended if we repair or replace the product. We may change the availability of this limited warranty at our discretion, but any changes will not be retroactive.

What Are Your Remedies Under This Warranty? With respect to any product that we have verified is defective in materials or workmanship based on a claim made during the applicable Warranty Period, we will, in our sole discretion, either: (a) repair or replace such product (or the defective part) free of charge or (b) refund the purchase price of such product. We will also pay for shipping and handling fees to return the repaired or replacement product to you if we elect to repair or replace the defective product.

How Do You Obtain Warranty Service? To obtain warranty service, you must call 1-888-421-0616 or e-mail support@luminsmart.com during the Warranty Period to make a warranty claim. We will evaluate the claim and may require you to provide information and documentation to substantiate the claim, in our discretion. If we determine in our reasonable discretion that your claim is valid, we will provide you with a Defective Merchandise Authorization ("DMA") number, which you can use to procure a repair, replacement, or refund, as described above, in our discretion. No warranty service will be provided without a DMA number.

Limitation of Liability. The remedies described above are your sole and exclusive remedies and our entire liability for any breach of this Limited Warranty. Notwithstanding anything to the contrary, our liability shall under no circumstances exceed the actual amount paid by you for the defective product, nor shall we under any circumstances be liable for any consequential, incidental, special or punitive damages or losses, whether direct or indirect. Some states do not allow the exclusion or limitation of incidental or consequential damages, so the above limitation or exclusion may not apply to you.

RADIO FREQUENCY STATEMENT

This device complies with Part 15 of the FCC rules and with Innovation, Science and Economic Development Canada's licence-exempt RSS(s). Operation is subject to the following two conditions:

1. This device may not cause interference.
2. This device must accept any interference, including interference that may cause undesired operation of the device.

L'émetteur/récepteur exempt de licence contenu dans le présent appareil est conforme à la partie 15 des règles de la FCC et aux CNR d'Innovation, Sciences et Développement économique Canada applicables aux appareils radio exempts de licence. L'exploitation est autorisée aux deux conditions suivantes:

1. L'appareil ne doit pas produire de brouillage;
2. L'appareil doit accepter tout brouillage radioélectrique subi, même si le brouillage est susceptible d'en compromettre le fonctionnement.

Changes or modifications not expressly approved by the party responsible for compliance could void the user's authority to operate the equipment.

The antennas used for this transmitter must be installed to provide a separation distance of at least 20cm from all persons and must not be located or operating in conjunction with any other antenna or transmitter.

Les antennes utilisées pour ce transmetteur doivent être installé en considérant une distance de séparation de toute personnes d'au moins 20 cm et ne doivent pas être localisé ou utilisé en conflit avec tout autre antenne ou transmetteur.

This radio transmitter 27016-LSP12WE (PMN: Lumin Smart Panel; HVIN: 8223A-SR) has been approved by Innovation, Science and Economic Development Canada to operate with the antenna types listed below, with the maximum permissible gain indicated. Antenna types not included in this list that have a gain greater than the maximum gain indicated for any type listed are strictly prohibited for use with this device.

1. Dipole type antenna, 2dBi maximum gain, 50 Ohm impedance

NOTE: This equipment has been tested and found to comply with the limits for a Class B digital device, pursuant to part 15 of the FCC Rules. These limits are designed to provide reasonable protection against harmful interference in a residential installation. This equipment generates, uses and can radiate radio frequency energy and, if not installed and used in accordance with the instructions, may cause harmful interference to radio communications. However, there is no guarantee that interference will not occur in a particular installation. If this equipment does cause harmful interference to radio or television reception, which can be determined by turning the equipment off and on, the user is encouraged to try to correct the interference by one or more of the following measures: (1) Reorient or relocate the receiving antenna. (2) Increase the separation between the equipment and receiver. (3) Connect the equipment into an outlet on a circuit different from that to which the receiver is connected. (4) Consult the dealer or an experienced radio/TV technician for help.



**501 Locust Ave, Floor 1, Suite 2
Charlottesville, VA 22902**

**SUPPORT@LUMINSMART.COM
1-888-421-0616
WWW.LUMINSMART.COM**

U.S. Patent No. 10,109,987
U.S. Patent No. 10,467,712
Canadian Patent No. 3,050,702
U.S. and International Patent Applications Pending.
® U.S. Registered Trademark.
Copyright © 2022 Coulomb, Inc. (DBA Lumin). All rights reserved.